

NOTES:

- 1.) ALL STL. MEMBERS COATED W/ ZINC RICH EPOXY THEN FINISHED W/ POLYESTER POWDER COATING.
- 2.) 1/2" X 3 3/4" EXPANSION ANCHOR BOLTS PROVIDED.
- 3.) BENCH IS SHIPPED UNASSEMBLED.



DuMor, inc.
P.O. Box 142 Mifflintown, PA 17059-0142

SCALE :	NONE
DATE DRAWN :	8/16/11
DRAWN BY :	JSB
DATE REV. :	
REV. BY :	

TITLE :	BENCH		
REV.	A	DRAWING NUMBER	426-34/S-5
			SHEET 1 OF 2

STEP 1 DETAIL

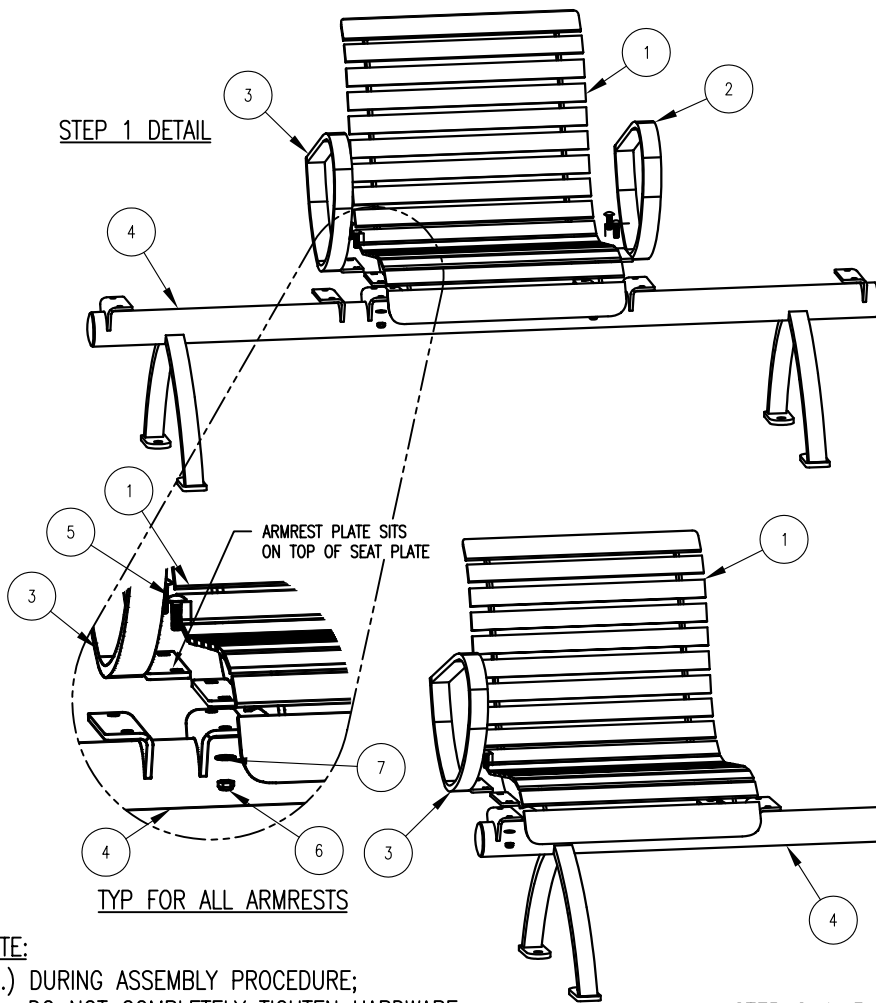

STEP 2 & 3 DETAIL

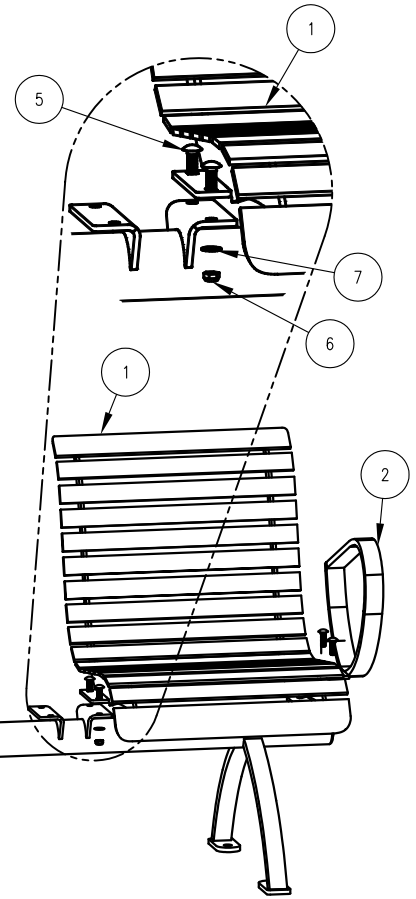

NOTE:

- 1.) DURING ASSEMBLY PROCEDURE;
DO NOT COMPLETELY TIGHTEN HARDWARE.
- 2.) THE ACTUAL PARTS WILL NOT BE NUMBERED;
NUMBERS ONLY APPLY TO DRAWING.

STEP 1:

- USE 1 - PC. SEAT SUPPORT FOR 3 SEATS. FREE STD (4)
 1 - PC. STL SEAT (20") (1)
 1 - PC. LEFT STL ARMREST (2)
 1 - PC. RIGHT STL ARMREST (3)
 4 - PCS. 3/8" X 1 1/4" SS. CGE BOLT (5)
 4 - PCS. 3/8" SS. THIN NYLON LOCKNUT (6)
 4 - PCS. 3/8" SS. FLAT WASHER (7)

ATTACH STL SEAT (20") (1), LEFT STL ARMREST (2) &
 RIGHT STL ARMREST (3) TO CENTER LOCATION OF SEAT
 SUPPORT FOR 3 SEATS, FREE STD (4). USING HARDWARE
 (5, 6 & 7). TIGHTEN TO SNUG FIT.

STEP 2:

- USE 1 - PC. STL SEAT (20") (1)
 1 - PC. LEFT STL ARMREST (2)
 4 - PCS. 3/8" X 1 1/4" SS. CGE BOLT (5)
 4 - PCS. 3/8" SS. THIN NYLON LOCKNUT (6)
 4 - PCS. 3/8" SS. FLAT WASHER (7)
- ATTACH STL SEAT (20") (1), LEFT STL ARMREST (2) TO STEP 1
 ASSEMBLY USING HARDWARE (5, 6 & 7). TIGHTEN TO SNUG FIT.

STEP 3:

- USE 1 - PC. STL SEAT (20") (1)
 1 - PC. RIGHT STL ARMREST (3)
 4 - PCS. 3/8" X 1 1/4" SS. CGE BOLT (5)
 4 - PCS. 3/8" SS. THIN NYLON LOCKNUT (6)
 4 - PCS. 3/8" SS. FLAT WASHER (7)

ATTACH STL SEAT (20") (1), RIGHT STL ARMREST (3) TO STEP 2
 ASSEMBLY USING HARDWARE (5, 6 & 7). TIGHTEN TO SNUG FIT.

STEP 4:

UPON COMPLETION OF BENCH ASSEMBLY SQUARE ALL
 COMPONENTS THEN TIGHTEN ALL HARDWARE.

STEP 5:

MOUNT AND ANCHOR AS SPECIFIED.

ITEM	QTY	PART NO	DESCRIPTION
1	3	0-426-00-01	STL SEAT (20")
2	2	0-424-00L-03	LEFT STL ARMREST
3	2	0-424-00R-03	RIGHT STL ARMREST
4	1	0-424-30-02/S-5	STL SEAT SUPPORT FOR 3 SEATS, FREE STD
5	12	1-11-019	3/8" X 1 1/4" SS CGE BOLT
6	12	1-20-019	3/8" SS THIN NYLON LOCKNUT
7	12	1-22-024	3/8" SS FLAT WASHER

DuMor, inc.
 P.O. Box 142 Mifflintown, PA 17059-0142

SCALE : NONE
 DATE DRAWN : 8/16/11
 DRAWN BY : JSB
 DATE REV. :
 REV. BY :

TITLE : BENCH ASSEMBLY

REV. A

DRAWING NUMBER 426-34/S-5

SHEET 2 OF 2