

S-2 SURFACE

LENGTH OPTIONS

- 6' BENCH
- 8' BENCH

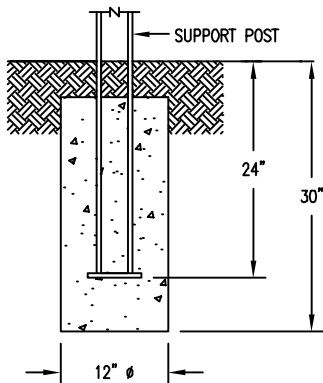
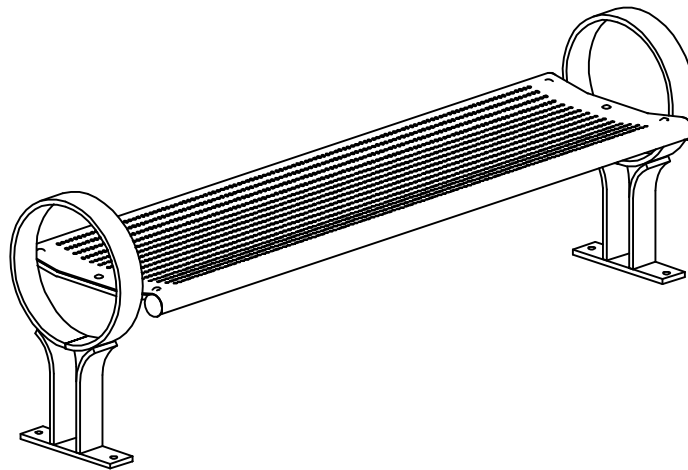

S-1 EMBEDMENT

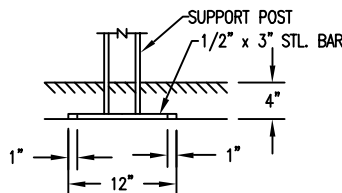

S-4 SUB FLOOR

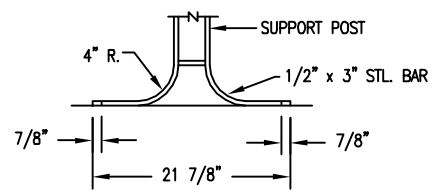

S-3 GULL WING

NOTES:

- 1.) ALL STL. MEMBERS COATED W/ ZINC RICH EPOXY THEN FINISHED W/ POLYESTER POWDER COATING.
- 2.) 1/2" X 3 3/4" EXPANSION ANCHOR BOLTS PROVIDED FOR S-2, S-3 & S-4 OPTIONS.

DuMor, inc.
 P.O. Box 142 Mifflintown, PA 17059-0142

SCALE : NONE
 DATE DRAWN : 12/12/96
 DRAWN BY : AH
 DATE REV. : 12/15/99
 REV. BY : JSB

TITLE : BENCH

REV. B

DRAWING NUMBER 104 SERIES

SHEET 1 OF 2

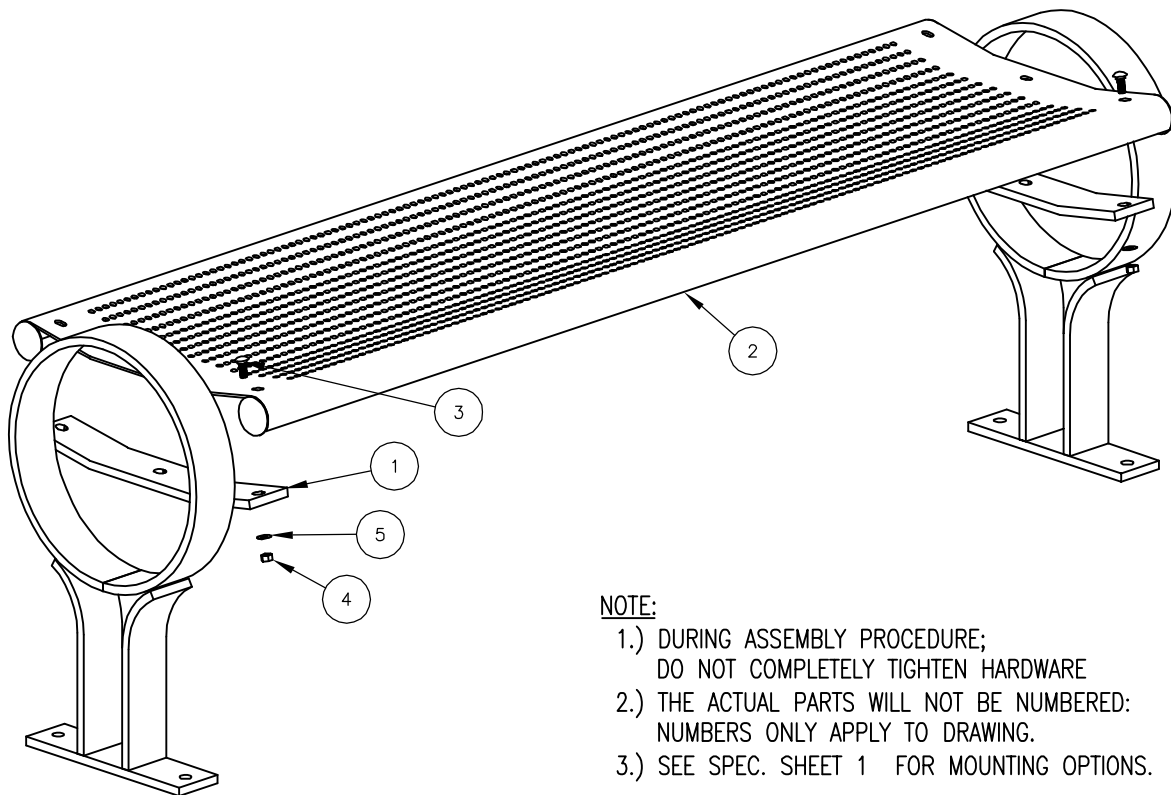

NOTE:

- 1.) DURING ASSEMBLY PROCEDURE;
DO NOT COMPLETELY TIGHTEN HARDWARE
- 2.) THE ACTUAL PARTS WILL NOT BE NUMBERED:
NUMBERS ONLY APPLY TO DRAWING.
- 3.) SEE SPEC. SHEET 1 FOR MOUNTING OPTIONS.

STEP 1:

USE 2 - PCS. SUPPORT FOR SURFACE MOUNT (1)
 1 - PC. 6' SEAT ASSEMBLY (2)
 6 - PCS. 3/8" X 1" SS. CGE. BOLT (3)
 6 - PCS. 3/8" SS. HEX NUT (4)
 6 - PCS. 3/8" SS. FLAT WASHER (5)
 ATTACH 6' SEAT ASSEMBLY (2) TO SUPPORT FOR
 SURFACE MOUNT (1) USING HARDWARE (3, 4 & 5).
 TIGHTEN TO SNUG FIT.

STEP 2:

UPON COMPLETION OF BENCH ASSEMBLY SQUARE ALL
 COMPONENTS THEN TIGHTEN ALL HARDWARE.

STEP 3:

ANCHOR ACCORDING TO SUPPORT OPTION USED.

ITEM	QTY	PART NO	DESCRIPTION
1	2	0-104-00-01/S-2	SUPPORT FOR SURFACE MOUNT
2	1	0-104-60-02	6' SEAT ASSEMBLY
3	6	1-11-028	3/8" X 1" SS CGE BOLT
4	6	1-21-007	3/8" SS HEX NUT
5	6	1-22-024	3/8" SS FLAT WASHER

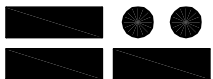
 DuMor, inc. P.O. Box 142 Mifflintown, PA 17059-0142	SCALE :	NONE	TITLE :		BENCH ASSEMBLY	
	DATE DRAWN :	12/12/96	REV.	DRAWING NUMBER	104 SERIES	SHEET 2 OF 2
	DRAWN BY :	AH	B			
	DATE REV. :	12/15/99				
REV. BY :	JSB					