

NOTES:

- 1.) ALL STL. MEMBERS COATED W/ ZINC RICH EPOXY THEN FINISHED W/ POLYESTER POWDER COATING.
- 2.) 1/2" X 3 3/4" EXPANSION ANCHOR BOLTS PROVIDED.

LENGTH OPTIONS

- 6' BENCH
- 8' BENCH

DuMor, inc.
P.O. Box 142 Mifflintown, PA 17059-0142

SCALE : NONE
DATE DRAWN : 9/30/97
DRAWN BY : AH
DATE REV. : 12/19/06
REV. BY : AWH

TITLE : BENCH

REV. D

DRAWING NUMBER 120 SERIES

SHEET 1 OF 2

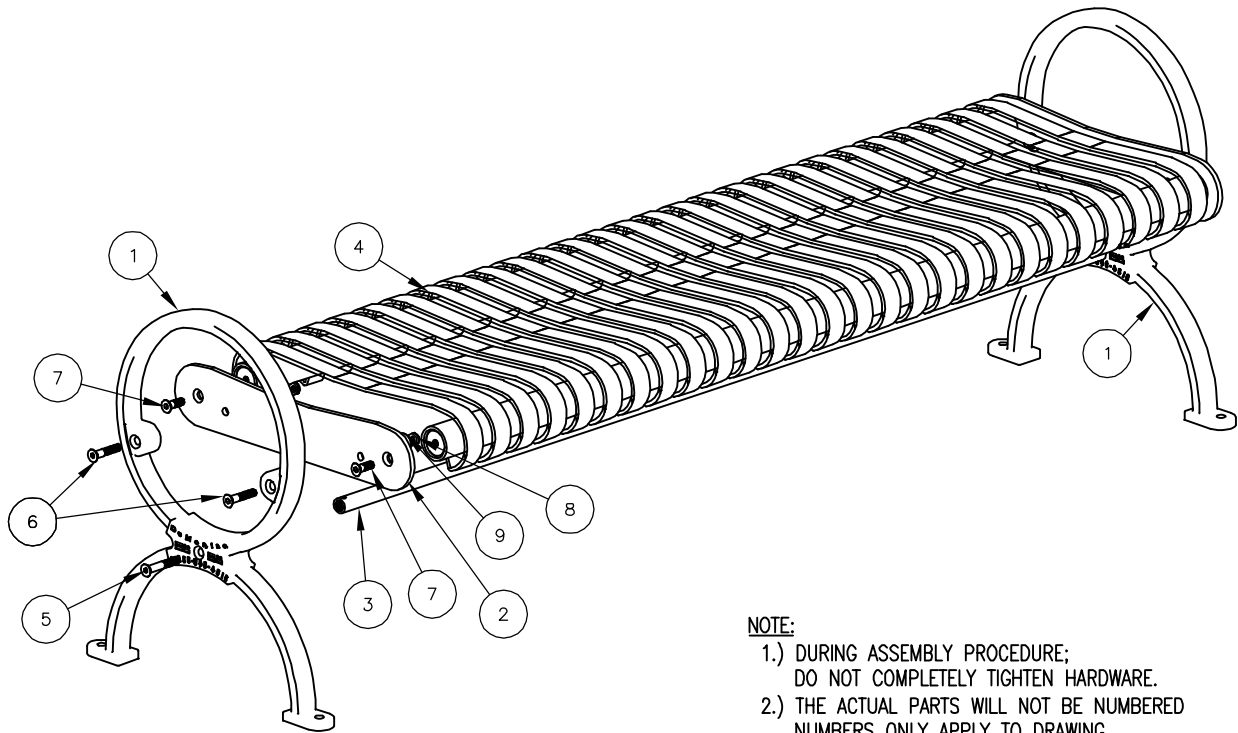

NOTE:
 1.) DURING ASSEMBLY PROCEDURE;
 DO NOT COMPLETELY TIGHTEN HARDWARE.
 2.) THE ACTUAL PARTS WILL NOT BE NUMBERED
 NUMBERS ONLY APPLY TO DRAWING.

STEP 1:

USE 1 - PC. 6' SEAT ASSEMBLY (4)
 2 - PCS. END PLATE (2)
 4 - PCS. 1/2" X 1 1/2" FLT. SKT. HD. CAP (7)
 ATTACH END PLATES (2) TO 6' SEAT ASSEMBLY (4)
 USING HARDWARE (7). TIGHTEN TO SNUG FIT.

STEP 2:

USE 2 - PCS. CAST IRON END SUPPORT (1)
 4 - PCS. 1/2" X 2 1/2" FLT. SKT. HD. CAP SCR. (6)
 4 - PCS. 1/2" SS. THIN NYLON LOCKNUT (8)
 4 - PCS. 1/2" SS. FLAT WASHER (9)
 ATTACH CAST IRON END SUPPORTS (1) TO STEP 1 ASSEMBLY
 USING HARDWARE (6, 8, & 9). TIGHTEN TO SNUG FIT.

STEP 3:

USE 1 - PC. 71 3/4" PIPE BRACE (3)
 2 - PCS. 1/2" X 3" FLT. SKT. HD. CAP SCR. (5)
 ATTACH 71 3/4" PIPE BRACE (3) TO STEP 2 ASSEMBLY
 USING HARDWARE (5). TIGHTEN TO SNUG FIT.

STEP 4:

UPON COMPLETION OF BENCH ASSEMBLY SQUARE
 ALL COMPONENTS THEN TIGHTEN ALL HARDWARE.

STEP 5:

MOUNT AND ANCHOR AS SPECIFIED.

ITEM	QTY	PART NO	DESCRIPTION
1	2	0-119-00-01	CAST IRON SUPPORT
2	2	0-120-00-02	END PLATE
3	1	0-57-60-04	71 3/4" PIPE BRACE
4	1	0-92-60-01	6' STL SEAT
5	2	1-12-037	1/2" X 3" SS FLT SKT HD CAP SCR
6	4	1-12-065	1/2" X 2 1/2" FLT SKT HD CAP SCR
7	4	1-12-074	1/2" X 1 1/2" SS FLT SKT HD CAP
8	4	1-20-018	1/2" SS THIN NYLON LOCKNUT
9	4	1-22-015	1/2" SS FLAT WASHER

DuMor, inc.
 P.O. Box 142 Mifflintown, PA 17059-0142

SCALE : NONE
 DATE DRAWN : 9/30/97
 DRAWN BY : AH
 DATE REV. : 12/19/06
 REV. BY : AWH

TITLE : BENCH ASSEMBLY

REV. D DRAWING NUMBER 120 SERIES

SHEET 2 OF 2