

NOTES:

- 1.) ALL STL. MEMBERS COATED W/ ZINC RICH EPOXY THEN FINISHED W/ POLYESTER POWDER COATING.
- 2.) ALL WELDS CONT. THEN GROUND SMOOTH.
- 3.) BENCH SHIPPED UNASSEMBLED.
- 4.) 1/2" X 3 3/4" EXPANSION ANCHOR BOLTS PROVIDED FOR S-2 OPTION.

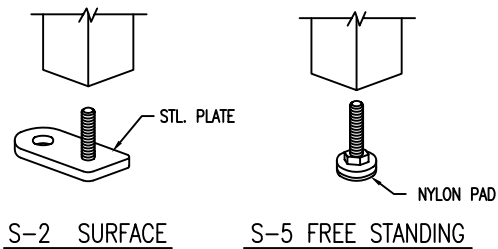

DuMor, inc.
 P.O. Box 142 Mifflintown, PA 17059-0142

SCALE : NONE
 DATE DRAWN : 3/22/94
 DRAWN BY : AH
 DATE REV. : 6/5/09
 REV. BY : AWH

TITLE : BENCH
 REV. E
 DRAWING NUMBER 94-60
 SHEET 1 OF 2

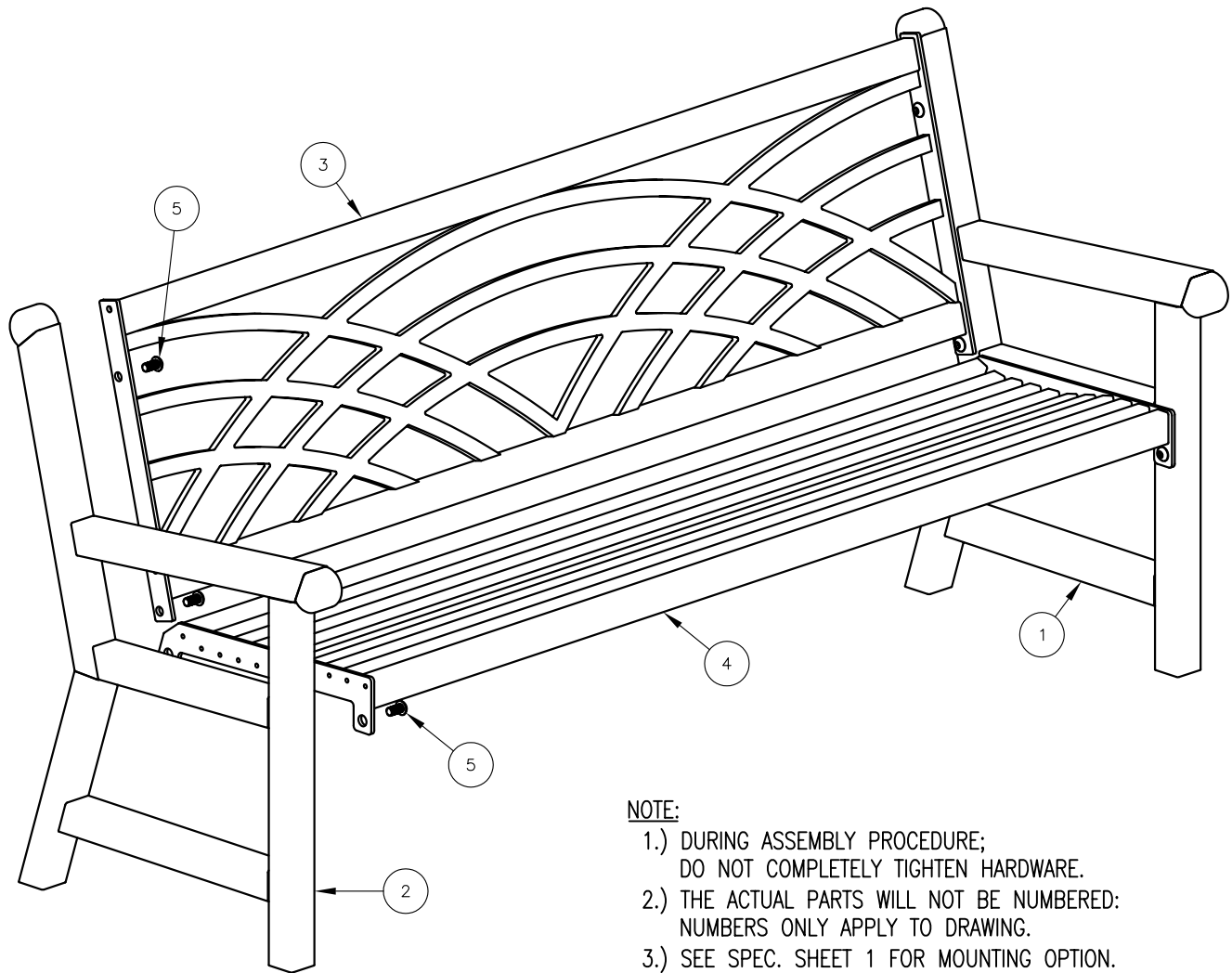

NOTE:

- 1.) DURING ASSEMBLY PROCEDURE;
DO NOT COMPLETELY TIGHTEN HARDWARE.
- 2.) THE ACTUAL PARTS WILL NOT BE NUMBERED:
NUMBERS ONLY APPLY TO DRAWING.
- 3.) SEE SPEC. SHEET 1 FOR MOUNTING OPTION.

STEP 1:

- USE 1 - PC. ALL STL LEFT END SUPPORT (1)
 - 1 - PC. ALL STL RIGHT END SUPPORT (2)
 - 1 - PC. 6' ALL STL SEAT ASSEMBLY (4)
 - 4 - PCS. 1/2" X 1" SS. BTN. SKT. HD. CAP SCR. (5)
- ATTACH ALL STL LEFT END SUPPORT (1) AND ALL STL RIGHT END SUPPORT (2) TO 6' ALL STL SEAT ASSEMBLY (4) USING HARDWARE (5). TIGHTEN TO SNUG FIT.

STEP 2:

- USE 1 - PC. 6' ALL STL BACK ASSEMBLY (3)
 - 4 - PCS. 1/2" X 1" SS. BTN. SKT. HD. CAP SCR. (5).
- ATTACH 6' ALL STL BACK ASSEMBLY (3) TO STEP 1 ASSEMBLY USING HARDWARE (5). TIGHTEN TO SNUG FIT.

STEP 3:

UPON COMPLETION OF BENCH ASSEMBLY SQUARE ALL COMPONENTS THEN TIGHTEN ALL HARDWARE.

STEP 4:

ANCHOR ACCORDING TO SUPPORT OPTION USED.

ITEM	QTY	PART NO	DESCRIPTION
1	1	0-94-00L-01	STL LEFT END SUPPORT
2	1	0-94-00R-01	STL RIGHT END SUPPORT
3	1	0-94-60-03	6' STL BACK
4	1	0-94-60-04	6' STL SEAT
5	8	1-12-056	1/2" X 1" SS BTN SKT HD CAP SCR



DuMor, inc.
P.O. Box 142 Mifflintown, PA 17059-0142

SCALE : NONE
DATE DRAWN : 11/15/99
DRAWN BY : JSB
DATE REV. : 6/5/09
REV. BY : AWH

TITLE : BENCH ASSEMBLY

REV. E	DRAWING NUMBER 94-60	SHEET 2 OF 2
--------	----------------------	--------------