

LENGTH OPTIONS

- 6' BENCH
- 8' BENCH

NOTES:

- 1.) ALL STL. MEMBERS COATED W/ ZINC RICH EPOXY THEN FINISHED W/ POLYESTER POWDER COATING.
- 2.) BENCH IS SHIPPED UNASSEMBLED.
- 3.) 1/2" X 3 3/4" EXPANSION ANCHOR BOLTS PROVIDED

DuMor, inc.
P.O. Box 142 Mifflintown, PA 17059-0142

SCALE : NONE
DATE DRAWN : 8/8/11
DRAWN BY : JSB
DATE REV. :
REV. BY :

| | | | |
|-------------------------|--|-------------------------------------|------------------------|
| TITLE : BENCH | | DRAWING NUMBER 191 SERIES | SHEET 1 OF 2 |
| REV. A | | | |

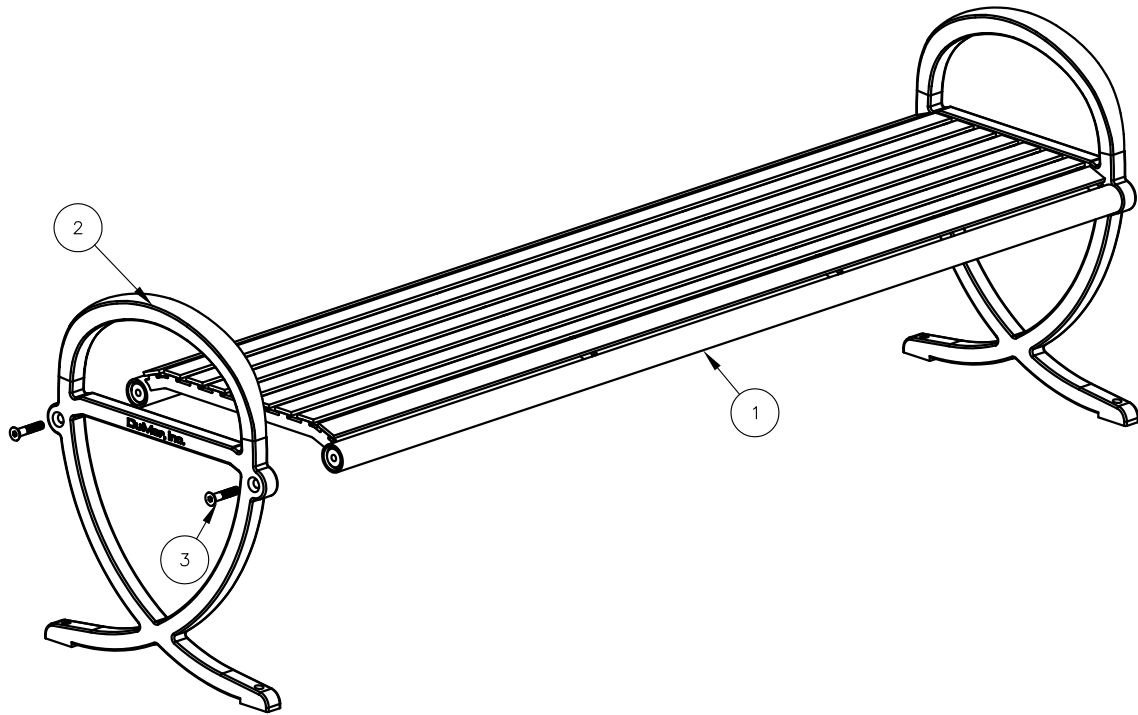

NOTE:

- 1.) DURING ASSEMBLY PROCEDURE;
DO NOT COMPLETELY TIGHTEN HARDWARE.
- 2.) THE ACTUAL PARTS WILL NOT BE NUMBERED:
NUMBERS ONLY APPLY TO DRAWING.

STEP 1:

USE 2 - PCS. BKLESS CAST IRON BENCH SUPPORT (2)
 1 - PC. 6' ALL STL SEAT (1)
 4 - PCS. 1/2" X 2 1/2" FLT. SKT. HD. CAP SCR. (3)
 ATTACH BKLESS CAST IRON SUPPORT (2) TO 6' ALL STL SEAT ASSEMBLY
 (1) USING HARDWARE (3). TIGHTEN TO SNUG FIT.

STEP 2:

UPON COMPLETION OF BENCH ASSEMBLY SQUARE ALL
 COMPONENTS THEN TIGHTEN ALL HARDWARE.

STEP 3:

MOUNT AND ANCHOR AS SPECIFIED.

| ITEM | QTY | PART NO | DESCRIPTION |
|------|-----|-------------|----------------------------------|
| 1 | 1 | 0-164-60-02 | 6' STL SEAT |
| 2 | 2 | 0-191-00-01 | BKLESS CAST IRON BENCH SUPPORT |
| 3 | 4 | 1-12-065 | 1/2" X 2 1/2" FLT SKT HD CAP SCR |

| | | | | | |
|---|--------------|--------|----------------------|-------------------------------------|---------------------|
|  | SCALE : | NONE | TITLE : BENCH | | |
| | DATE DRAWN : | 8/8/11 | | | |
| | DRAWN BY : | JSB | REV. A | DRAWING NUMBER 191 SERIES | SHEET 2 OF 2 |
| | DATE REV. : | | | | |
| | REV. BY : | | | | |