

S-2 SURFACE

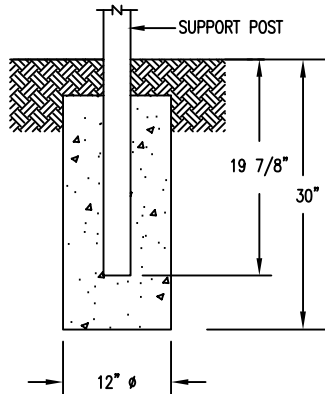

S-1 EMBEDMENT

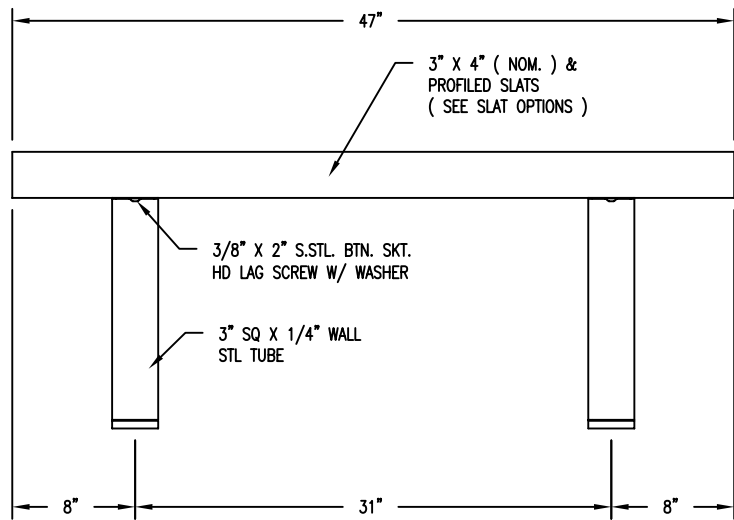
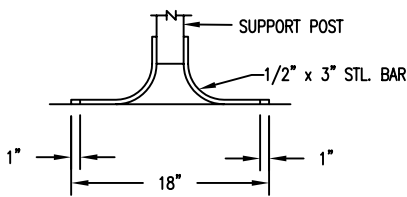
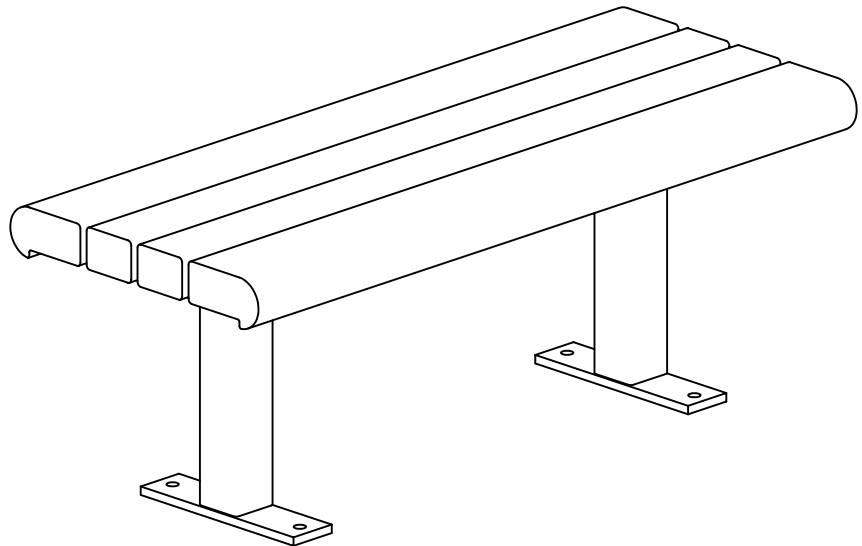

S-3 GULL WING

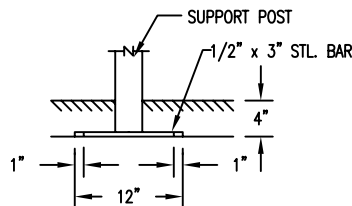

S-4 SUB FLOOR

SLAT OPTIONS

- "CEDAR" RECYCLED PLASTIC
- "GREY" RECYCLED PLASTIC
- "REDWOOD" RECYCLED PLASTIC
- "WALNUT" RECYCLED PLASTIC
- OTHER _____

NOTES

- 1.) ALL STL. MEMBERS COATED W/ ZINC RICH EPOXY THEN FINISHED W/ POLYESTER POWDER COATING.
- 2.) 1/2" X 3 3/4" EXPANSION ANCHOR BOLT PROVIDED FOR S-2, S-3 & S-4 OPTIONS.



DuMor, inc.
 P.O. Box 142 Mifflintown, PA 17059-0142

SCALE : NONE
 DATE DRAWN : 4/27/01
 DRAWN BY : CDC
 DATE REV. : 10/26/11
 REV. BY : JSB

TITLE : BENCH

REV. E	DRAWING NUMBER 103-40PL	SHEET 1 OF 2
--------	-------------------------	--------------

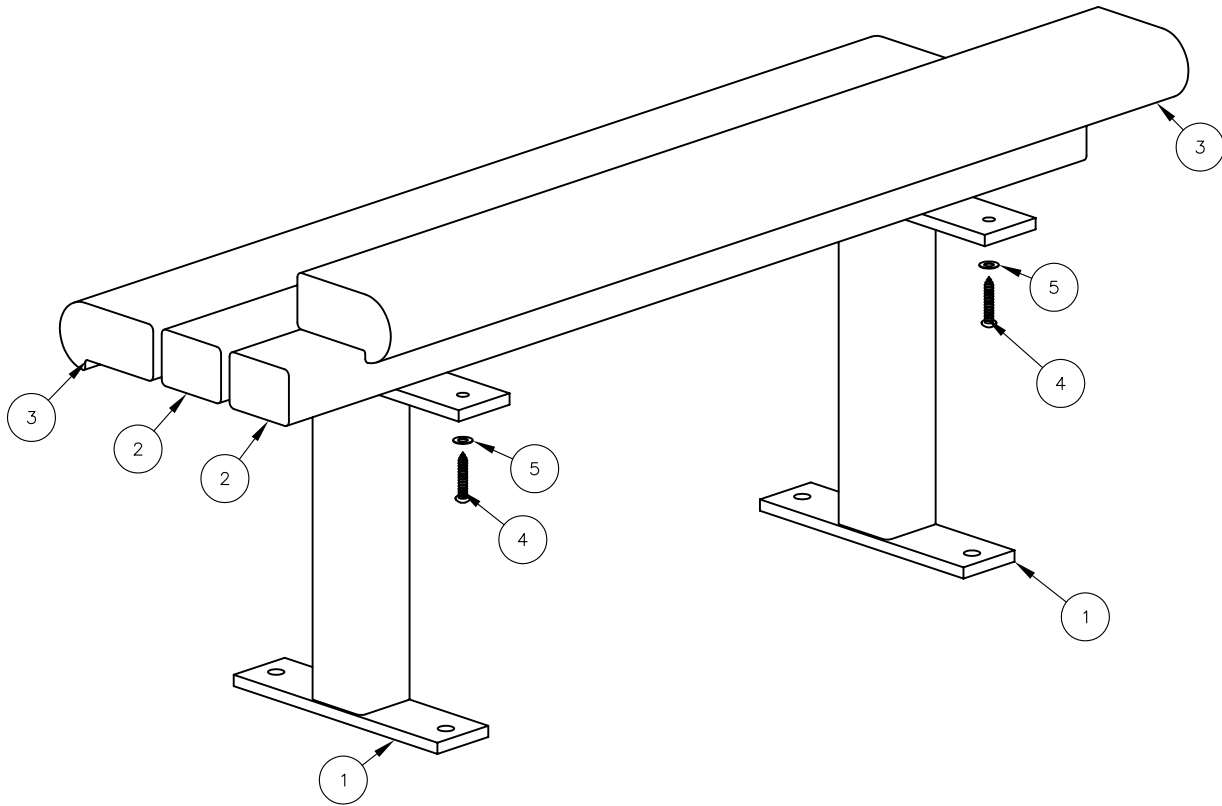
SURFACE MOUNT
OPTION SHOWN



NOTE:

- 1.) DURING ASSEMBLY PROCEDURE;
DO NOT COMPLETELY TIGHTEN HARDWARE.
- 2.) THE ACTUAL PARTS WILL NOT BE NUMBERED:
NUMBERS ONLY APPLY TO DRAWING.
- 3.) SEE SPEC. SHEET 1 FOR MOUNTING OPTIONS.

STEP 1:

USE 3 - PCS. SUPPORT FOR SURFACE MOUNT (1)
 2 - PCS. 3" X 4" X 47" PLASTIC INT'R SLAT (2)
 2 - PCS. 47" PLASTIC EDGE SLAT (3)
 12 - PCS. 3/8" X 2" SS. BTN. SKT. HD. LAG SCR. (4)
 12 - PCS. 3/8" SS. FLAT WASHER (5)
 ATTACH SLATS (2 & 3) TO SUPPORT FOR SURFACE MOUNT
 (1) USING HARDWARE (4 & 5). TIGHTEN TO SNUG FIT.
 REPEAT UNTIL ALL SLATS ARE ATTACHED.

STEP 2:

UPON COMPLETION OF BENCH ASSEMBLY SQUARE ALL
 COMPONENTS THEN TIGHTEN ALL HARDWARE.

STEP 3:

ANCHOR ACCORDING TO SUPPORT OPTION USED.

ITEM	QTY	PART NO	DESCRIPTION
1	2	0-103-00-01/S-2	SUPPORT FOR SURFACE MOUNT
2	2	0-88-40PL-02	3" X 4" X 47" PLASTIC SLAT
3	2	0-88-40PL-03	47" PLASTIC EDGE SLAT
4	8	1-13-016	3/8" X 2" SS BTN SKT HD LAG SCR
5	8	1-22-024	3/8" SS FLAT WASHER

DuMor, inc.
 P.O. Box 142 Mifflintown, PA 17059-0142

SCALE : NONE
 DATE DRAWN : 4/27/01
 DRAWN BY : CDC
 DATE REV. : 4/12/10
 REV. BY : AWH

TITLE : BENCH ASSEMBLY

REV. D DRAWING NUMBER 103-40PL

SHEET 2 OF 2