

SLAT OPTIONS

- "CEDAR" RECYCLED PLASTIC
- "GREY" RECYCLED PLASTIC
- "REDWOOD" RECYCLED PLASTIC
- "WALNUT" RECYCLED PLASTIC
- OTHER _____

FINISH OPTIONS:

- ALL STL. MEMBERS COATED W/ ZINC RICH EPOXY THEN FINISHED W/ POLYESTER POWDER COATING.
- HOT DIP GALV. AFTER FABRICATION.

LENGTH OPTIONS

- 6' TABLE
- 8' TABLE

NOTES:

- 1.) 1/2" X 3 3/4" EXPANSION ANCHOR BOLTS PROVIDED.



PICNIC TABLE

DATE DRAWN : 03/22/94
 DRAWN BY : AWH
 DATE REV. : 01/11/17
 REV. BY : RDH

REV.
H

DRAWING NUMBER

77 SERIES PL

SHEET
1 OF 2

NOTES:

- 1.) DURING ASSEMBLY PROCEDURE;
DO NOT COMPLETELY TIGHTEN HARDWARE.
- 2.) THE ACTUAL PARTS WILL NOT BE NUMBERED.
NUMBERS ONLY APPLY TO DRAWING.
- 3.) UPON COMPLETION OF ASSEMBLY SQUARE
ALL COMPONENTS THEN TIGHTEN ALL HARDWARE.
- 4.) MOUNT AND ANCHOR AS SPECIFIED.

TOOLS REQ'D

- 1/2" WRENCH
- 3/4" WRENCH

PARTS LIST

ITEM	QTY	PART NO	DESCRIPTION
1	5	0-71-60PL-01	2" X 10" X 71" SLAT, PLASTIC
2	2	0-77-00-01	END SUPPORT FRAME
3	2	0-77-60-02	DIAGONAL BRACE FOR 6' TABLE
4	2	0-77-60-14	6' SEAT BRACE
5	1	0-77-60-15	6' TABLE TOP BRACE
6	30	1-11-062	5/16" X 2 1/4" SS CGE BOLT
7	4	1-12-061	5/16" X 1" SS HEX HD CAP SCR
8	4	1-20-016	5/16" SS NYLON LOCKNUT
9	30	1-21-015	5/16" SS HEX NUT
10	38	1-22-017	5/16" SS FLAT WASHER

KITS PROVIDED

ITEM	QTY	PART NO	DESCRIPTION
11	1	K-77PL	77PL SER HARDWARE KIT
12	1	K-ANCO860-4	1/2" X 3 3/4" SS ANCHOR KIT (4PC)

① ATTACH SUPPORT FRAMES TO SLATS. BE SURE TABLE & SEAT BRACES ARE BETWEEN SLATS & SUPPORT FRAMES.

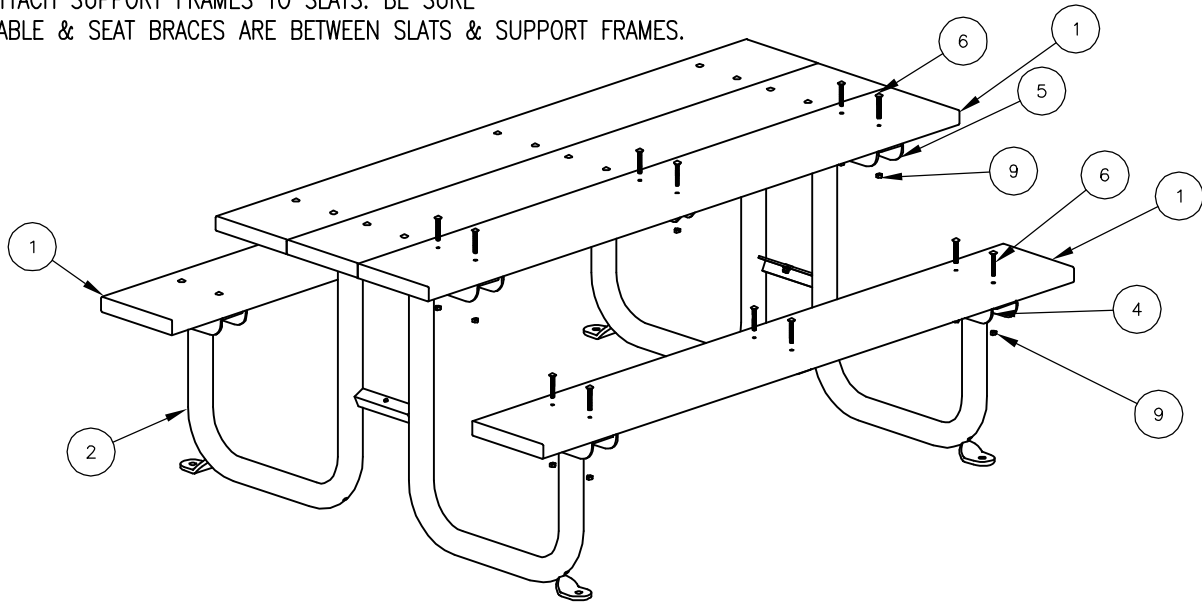

② ATTACH DIAGONAL BRACES TO STEP 1 ASSEMBLY.

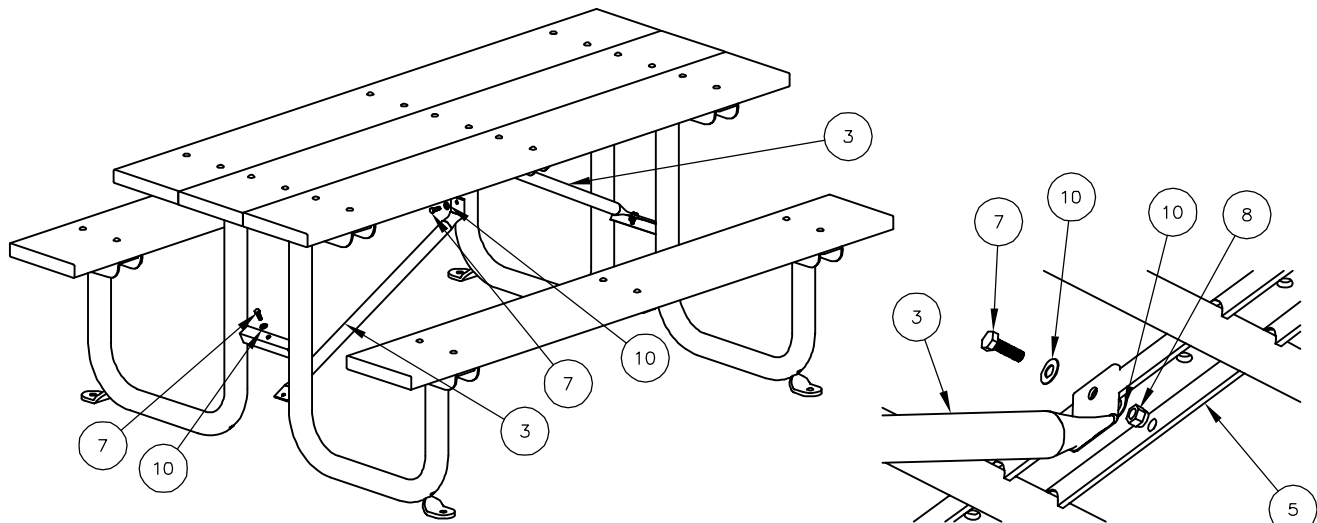

UNDERSIDE OF TABLE DETAIL