

NOTES:

- 1.) ALL STL. MEMBERS COATED W/ ZINC RICH EPOXY THEN FINISHED W/ POLYESTER POWDER COATING.
- 2.) 1/2" X 3 3/4" EXPANSION ANCHOR BOLTS PROVIDED.
- 3.) LATCH PROVIDED W/ KEY, USE OF KEY OPTIONAL.



RECEPTACLE

DATE DRAWN : 01/03/13
 DRAWN BY : JSB
 DATE REV. : 00/00/00
 REV. BY : XXX

REV.
A

DRAWING NUMBER

157-32
W/ CVB-30-FTO

SHEET
1 OF 2

NOTES:

- 1.) DURING ASSEMBLY PROCEDURE;
DO NOT COMPLETELY TIGHTEN HARDWARE.
- 2.) THE ACTUAL PARTS WILL NOT BE NUMBERED.
NUMBERS ONLY APPLY TO DRAWING.
- 3.) UPON COMPLETION OF ASSEMBLY SQUARE
ALL COMPONENTS THEN TIGHTEN ALL HARDWARE.
- 4.) MOUNT AND ANCHOR AS SPECIFIED.

TOOLS REQ'D

- 3/4" WRENCH
- 1/2" WRENCH
- 3/16" ALLEN WRENCH
- 1/2" MASONRY DRILL BIT
DRILL

PARTS LIST

ITEM	QTY	PART NO	DESCRIPTION
1	1	0-157-30	30 GAL RECEPTACLE ASSEMBLY
2	3	1-12-023	5/16" X 1" SS FLT SKT HD CAP SCR
3	3	1-20-016	5/16" SS NYLON LOCKNUT
4	3	1-22-017	5/16" SS FLAT WASHER
5	1	49-32	32 GAL PL LINER W/ HANDLE, BLK

KITS PROVIDED

ITEM	QTY	PART NO	DESCRIPTION
7	1	K-ANC0860-3	1/2" X 3 3/4" SS ANCHOR KIT (3PCS)
8	1	K-FC0516-3L	5/16" CAP HARDWARE KIT (3 PCS)

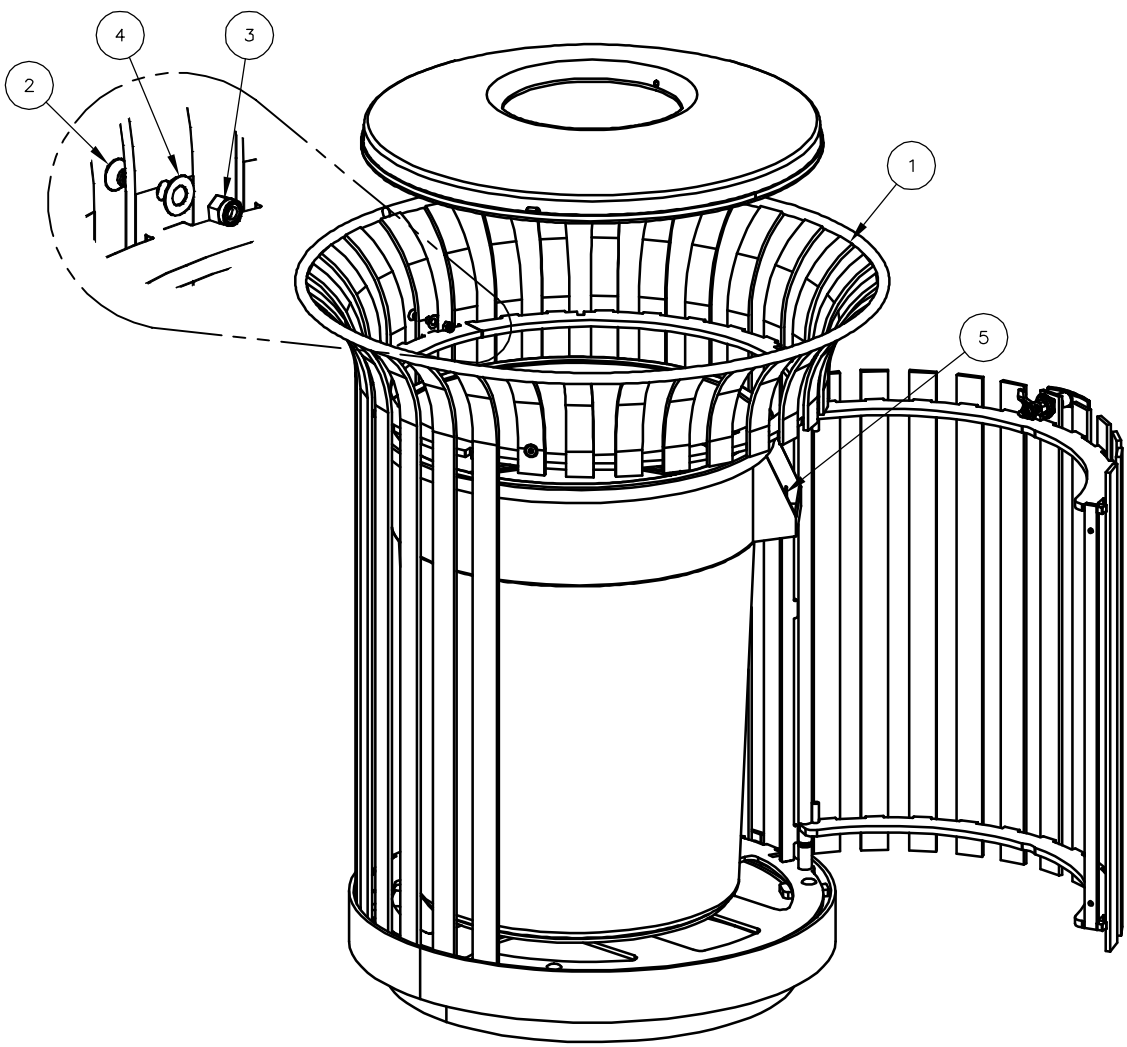

ASSEMBLY
INSTRUCTIONS

DATE DRAWN : 01/03/13
 DRAWN BY : JSB
 DATE REV. : 00/00/00
 REV. BY : XXX

REV.
A

DRAWING
NUMBER

157-32
W/ CVB-30-FTO

SHEET
2 OF 2