

□ S-2 SURFACE

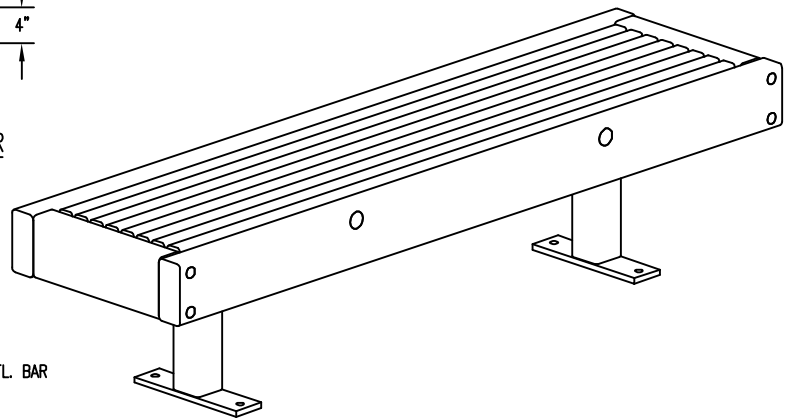

NOTES

- 1.) ALL STL. MEMBERS COATED W/ ZINC RICH EPOXY THEN FINISHED W/ POLYESTER POWDER COATING.
- 2.) ALL WOOD MEMBERS TREATED W/ CLEAR PRESERVATIVE.
- 3.) SEAT PORTION SHIPPED FULLY ASSEMBLED.
- 4.) 1/2" X 3 3/4" EXPANSION ANCHOR BOLTS PROVIDED FOR S-2, S-3 & S-4 OPTIONS.

WOOD OPTIONS

- IPE S4S EE
- 'C' & BTR. DOUGLAS FIR KD S4S EE
- OTHER _____

DuMor, inc.
P.O. Box 142 Mifflintown, PA 17059-0142

SCALE : NONE
DATE DRAWN : 3/22/94
DRAWN BY : AH
DATE REV. : 10/27/11
REV. BY : RDH

TITLE : BENCH

REV. G

DRAWING NUMBER 37-60

SHEET 1 OF 2

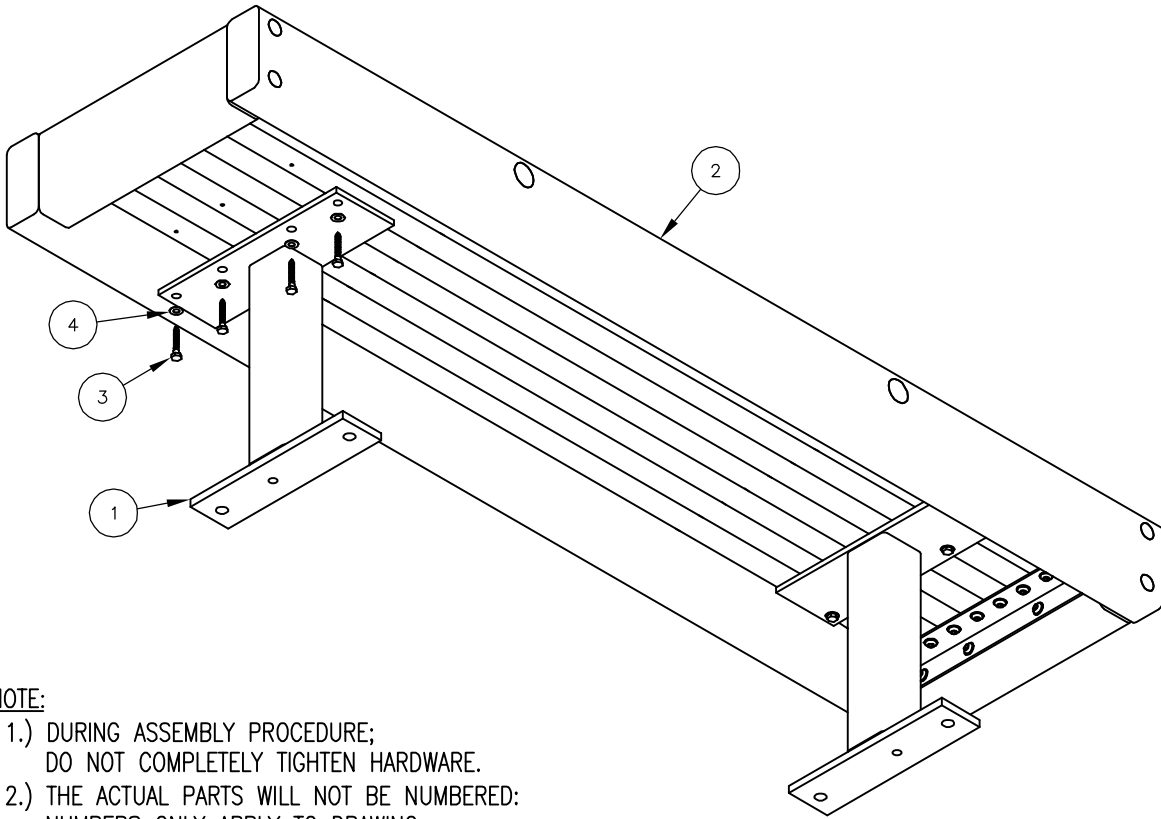

NOTE:

- 1.) DURING ASSEMBLY PROCEDURE;
DO NOT COMPLETELY TIGHTEN HARDWARE.
- 2.) THE ACTUAL PARTS WILL NOT BE NUMBERED;
NUMBERS ONLY APPLY TO DRAWING.
- 3.) SEE SPEC. SHEET 1 FOR MOUNTING OPTIONS.

STEP 1:

USE 2 - PC. SUPPORT FOR SURFACE MOUNT (1)
 1 - PC. SEAT ASSEMBLY (2)
 8 - PCS. 5/16" X 2" SS. HEX LAG (3)
 8 - PCS. 5/16" SS. FLAT WASHER (4)
 ATTACH SUPPORTS FOR SURFACE MOUNT (1) TO SEAT ASSEMBLY
 (2) USING HARDWARE (3 & 4). TIGHTEN TO SNUG FIT.

STEP 2:

UPON COMPLETION OF BENCH ASSEMBLY SQUARE ALL
 COMPONENTS THEN TIGHTEN ALL HARDWARE.

STEP 3:

ANCHOR ACCORDING TO SUPPORT OPTION USED.

ITEM	QTY	PART NO	DESCRIPTION
1	2	0-37-00-02/S-2	SUPPORT FOR SURFACE MOUNT
2	1	0-37-60-01	6' SEAT ASSEMBLY
3	8	1-13-038	5/16" X 2" SS HEX HD LAG SCR
4	8	1-22-017	5/16" SS FLAT WASHER

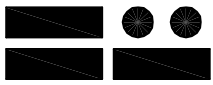
 DuMor, inc. P.O. Box 142 Mifflintown, PA 17059-0142	SCALE :	NONE	TITLE : <h2 style="margin: 0;">BENCH ASSEMBLY</h2>		
	DATE DRAWN :	3/22/94			
	DRAWN BY :	AH	REV. <h1 style="margin: 0;">G</h1>	DRAWING NUMBER <h2 style="margin: 0;">37-60</h2>	SHEET 2 OF 2
	DATE REV. :	10/27/11			
REV. BY :	RDH				