

S-2 SURFACE S-5 FREE STANDING

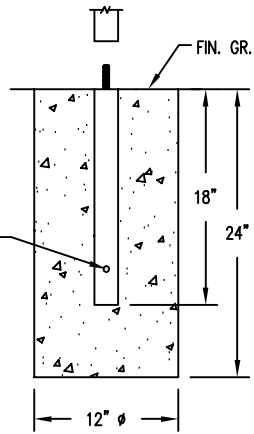

S-1 EMBEDMENT

WOOD OPTIONS

- 'C' & BTR. DOUGLAS FIR KD S4S EE
- IPE S4S EE
- OTHER _____

NOTES:

- 1.) ALL STL. MEMBERS COATED W/ ZINC RICH EPOXY THEN FINISHED W/ POLYESTER POWDER COATING.
- 2.) 1/2" X 3 3/4" EXPANSION ANCHOR BOLTS PROVIDED FOR S-2.



TABLE

DATE DRAWN : 11/22/17
 DRAWN BY : RDH
 DATE REV. :
 REV. BY :

REV.
A

DRAWING NUMBER

299-66

SHEET
1 OF 2

NOTES:

- 1.) DURING ASSEMBLY PROCEDURE;
DO NOT COMPLETELY TIGHTEN HARDWARE.
- 2.) THE ACTUAL PARTS WILL NOT BE NUMBERED.
NUMBERS ONLY APPLY TO DRAWING.
- 3.) UPON COMPLETION OF ASSEMBLY SQUARE
ALL COMPONENTS THEN TIGHTEN ALL HARDWARE.
- 4.) MOUNT AND ANCHOR AS SPECIFIED.

TOOLS REQ'D

- 3/4" WRENCH
- 3/16" ALLEN WRENCH
- 5/16" ALLEN WRENCH
- 1/2" MASONRY DRILL BIT
DRILL

PARTS LIST FOR S-2

ITEM	QTY	PART NO	DESCRIPTION
1	1	0-298-60-03	6' STL TABLE FRAME FOR WOOD
2	2	0-299-00-01	STL TABLE END SUPPORT
3	12	0-299-00-02	STL SEAT END SUPPORT
4	2	0-299-00-06	STL TABLE BRACE
5	6	0-299-19-03	6' STL SEAT SUB FRAME
6	6	0-299-19-04	6' BKLS STL SEAT FRAME FOR WOOD
7	24	0-299-19-07	2" X 3" X 17 3/4" SLAT, WOOD
8	1	0-299-60-03	6' STL TABLE SUB FRAME
9	8	0-472-60-03	71" INT'R SLAT, WOOD
10	28	0-94-00-02/S-2	SURFACE MOUNT FOOT PAD, PC
11	16	1-11-042	1/2" X 1 1/2" SS CGE BOLT
12	4	1-11-043	1/2" X 2" SS CGE BOLT
13	28	1-12-014	1/2" X 1" SS FLT SKT HD CAP SCR
14	2	1-12-030	1/2" X 1 1/2" SS BTN SKT HD CAP SCR
15	72	1-13-023	5/16" X 1 1/2" SS BTN SKT HD LAG
16	20	1-20-015	1/2" SS NYLON LOCKNUT
17	20	1-22-015	1/2" SS FLAT WASHER
18	72	1-22-017	5/16" SS FLAT WASHER

KITS PROVIDED FOR S-2

ITEM	QTY	PART NO	DESCRIPTION
19	7	K-ANC0860-4	1/2" X 3 3/4" SS ANCHOR KIT (4PC)
20	1	K-BC0824-2	1/2" CAP HARDWARE KIT (2PC)
21	2	K-BL0524-36	5/16" LAG HARDWARE KIT (36PC)
22	4	K-CG0824-4L	1/2" CGE BOLT HARDWARE KIT (4)
23	2	K-CG0832-2L	1/2" CGE BOLT HARDWARE KIT (2)
24	7	K-FC0816-4	1/2" CAP HARDWARE KIT (4 PCS)

1 ATTACH SUB FRAME TO END SUPPORTS.

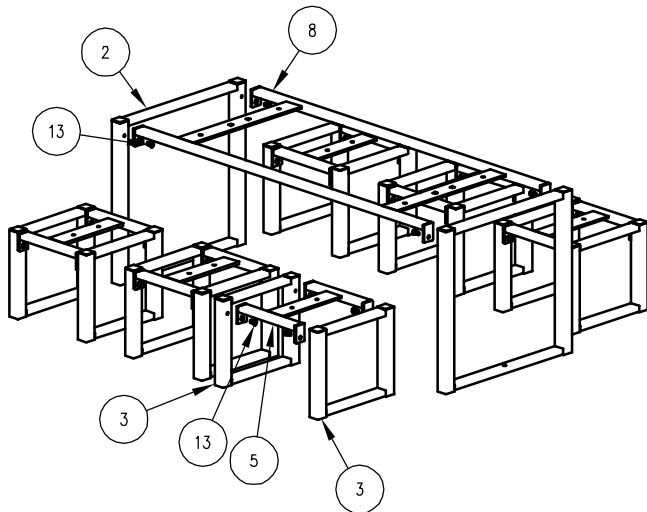

2 ATTACH TABLE & SEAT FRAMES TO STEP 1. ATTACH BRACE.

ADDITIONAL SEATS REMOVED FROM VIEW FOR CLARITY

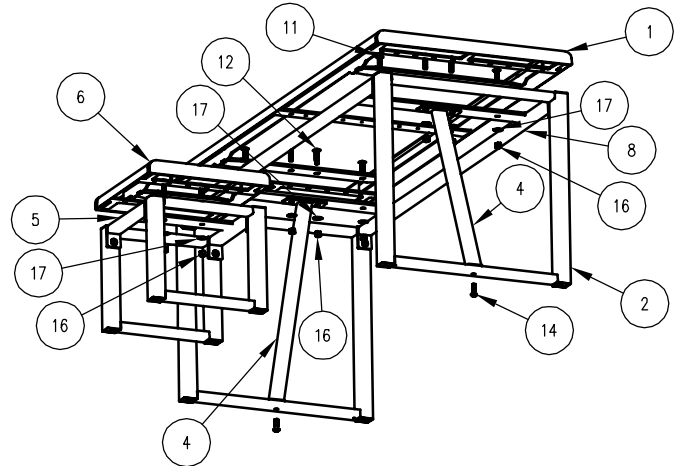

3 ATTACH SLATS TO STEP 2.

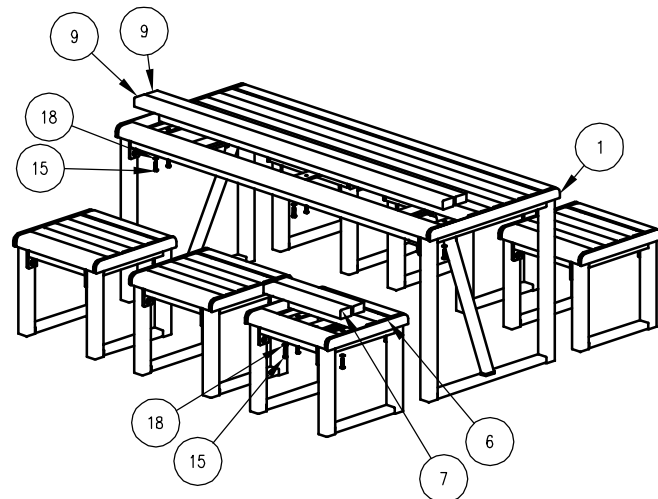

4 ATTACH SURFACE MOUNT FOOT PADS TO STEP 3.

