

S-2 SURFACE

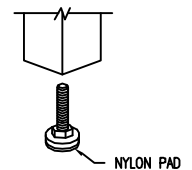

S-5 FREE STANDING

NOTES:

- 1.) ALL STL. MEMBERS COATED W/ ZINC RICH EPOXY THEN FINISHED W/ POLYESTER POWDER COATING.
- 2.) ALL WELDS CONT. THEN GROUND SMOOTH.
- 3.) BENCH SHIPPED UNASSEMBLED.
- 4.) 1/2" X 3 3/4" EXPANSION ANCHOR BOLTS PROVIDED FOR S-2 OPTION.

DuMor, inc.
 P.O. Box 142 Mifflintown, PA 17059-0142

SCALE : NONE
 DATE DRAWN : 9/10/97
 DRAWN BY : AH
 DATE REV. : 12/11/98
 REV. BY : JSB

TITLE : BENCH
 REV. C
 DRAWING NUMBER 118-80
 SHEET 1 OF 2

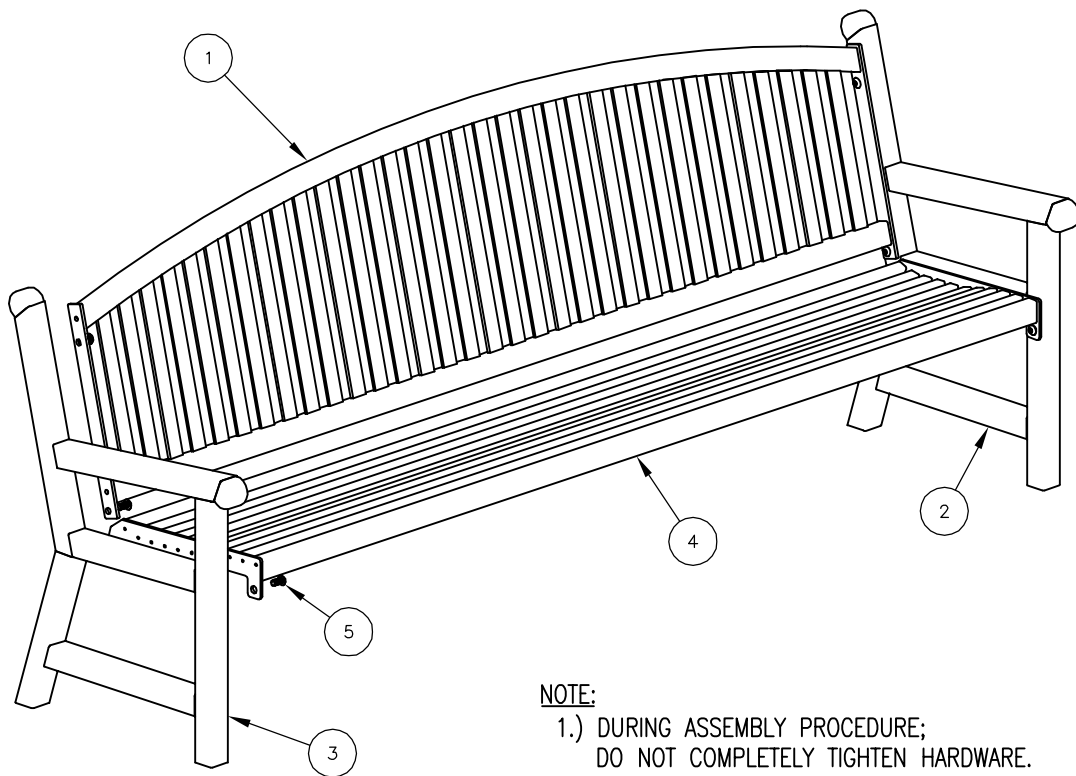

NOTE:

- 1.) DURING ASSEMBLY PROCEDURE;
DO NOT COMPLETELY TIGHTEN HARDWARE.
- 2.) THE ACTUAL PARTS WILL NOT BE NUMBERED;
NUMBERS ONLY APPLY TO DRAWING.
- 3.) SEE SPEC. SHEET 1 FOR MOUNTING OPTION.

STEP 1:

- USE 1 - PC. 8' ALL STL. SEAT ASSEMBLY (4)
- 1 - PC. ALL STL. LEFT END SUPPORT (2)
- 1 - PC. ALL STL. RIGHT END SUPPORT (3)
- 4 - PCS. 1/2" X 1" SS. BTN. SKT. HD. CAP SCR. (5)

ATTACH ALL STL. LEFT SUPPORT (2) & ALL STL. RIGHT SUPPORT (3) TO 8' ALL STL. SEAT ASSEMBLY (4) USING HARDWARE (5). TIGHTEN TO SNUG FIT.

STEP 2:

- USE 1 - PC. 8' ALL STL. BACK ASSEMBLY (1)
- 4 - PCS. 1/2" X 1" SS. BTN. SKT. HD. CAP SCR. (5)

ATTACH 8' ALL STL. BACK ASSEMBLY (1) TO STEP 1 ASSEMBLY USING HARDWARE (5). TIGHTEN TO SNUG FIT.

STEP 3:

UPON COMPLETION OF BENCH ASSEMBLY SQUARE ALL COMPONENTS THEN TIGHTEN ALL HARDWARE.

STEP 4:

ANCHOR ACCORDING TO SUPPORT OPTION USED.

ITEM	QTY	PART NO	DESCRIPTION
1	1	0-118-80-01	8' ALL STL BACK ASSEMBLY
2	1	0-94-00L-01	STL LEFT END SUPPORT
3	1	0-94-00R-01	STL RIGHT END SUPPORT
4	1	0-94-80-04	8' ALL STL SEAT ASSEMBLY
5	8	1-12-056	1/2" X 1" SS BTN SKT HD CAP SCR



DuMor, inc.

P.O. Box 142 Mifflintown, PA 17059-0142

SCALE : NONE

DATE DRAWN : 9/10/97

DRAWN BY : AH

DATE REV. : 12/11/98

REV. BY : JSB

TITLE : BENCH ASSEMBLY

REV.

DRAWING NUMBER

118-80

SHEET

2 OF 2