

SLAT OPTIONS

- ANTIQUE MAHOGANY TEXTURED
- BRAZILIAN WALNUT TEXTURED
- OTHER _____

NOTES:

- 1.) ALL STL. MEMBERS COATED W/ ZINC RICH EPOXY THEN FINISHED W/ POLYESTER POWDER COATING.
- 2.) 1/2" X 3 3/4" EXPANSION ANCHOR BOLTS PROVIDED.



BENCH

DATE DRAWN : 11/09/18
 DRAWN BY : ESS
 DATE REV. :
 REV. BY :

REV.
A

DRAWING NUMBER

91-40TX

SHEET
1 OF 2

PARTS LIST

ITEM	QTY	PART NO	DESCRIPTION
1	5	0-143-40TX-01	2" X 3" X 47" INT'R SLAT, TX
2	2	0-143-40TX-02	2" X 3" X 47" EDGE SLAT, TX
3	2	0-16-40-06	47" SEAT BRACE
4	1	0-57-40-04	47 3/4" PIPE BRACE
5	2	0-91-00-02	BKLESS CAST IRON BNCH SUPT
6	1	0-91-00-03	CENTER STRAP
7	2	0-91-00-04	END CONTOUR STRAP
8	6	1-12-065	1/2" X 2 1/2" FLT SKT HD CAP SCR
9	6	1-12-116	5/16" X 1" SS BTN SKT HD CAP SCR
10	21	1-13-023	5/16" X 1 1/2" SS BTN SKT HD LAG
11	6	1-20-016	5/16" SS NYLON LOCKNUT
12	33	1-22-017	5/16" SS FLAT WASHER

KITS PROVIDED

ITEM	QTY	PART NO	DESCRIPTION
13	1	K-147-40	147-40 SER HARDWARE KIT
14	1	K-ANCO860-4	1/2" X 3 3/4" SS ANCHOR KIT (4PC)
15	1	K-FC0840-6	1/2" CAP HARDWARE KIT (6PC)

NOTES:

- 1.) DURING ASSEMBLY PROCEDURE;
DO NOT COMPLETELY TIGHTEN HARDWARE.
- 2.) THE ACTUAL PARTS WILL NOT BE NUMBERED.
NUMBERS ONLY APPLY TO DRAWING.
- 3.) UPON COMPLETION OF ASSEMBLY SQUARE
ALL COMPONENTS THEN TIGHTEN ALL HARDWARE.
- 4.) MOUNT AND ANCHOR AS SPECIFIED.

TOOLS REQ'D

- 3/4" WRENCH
1/2" WRENCH
5/16" ALLEN WRENCH
1/4" ALLEN WRENCH
3/16" ALLEN WRENCH
1/2" MASONRY DRILL BIT
DRILL

- ① ATTACH CAST IRON BENCH SUPPORTS
TO PIPE BRACE, ATTACH END CONTOUR STRAPS

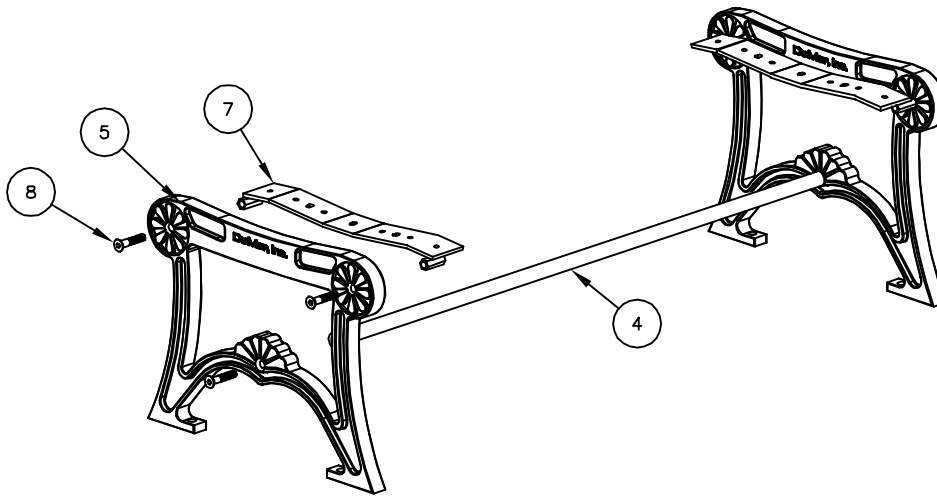

- ② ATTACH CENTER CONTOUR STRAP &
SEAT BRACES TO STEP 1 THROUGH SLOTTED HOLES.

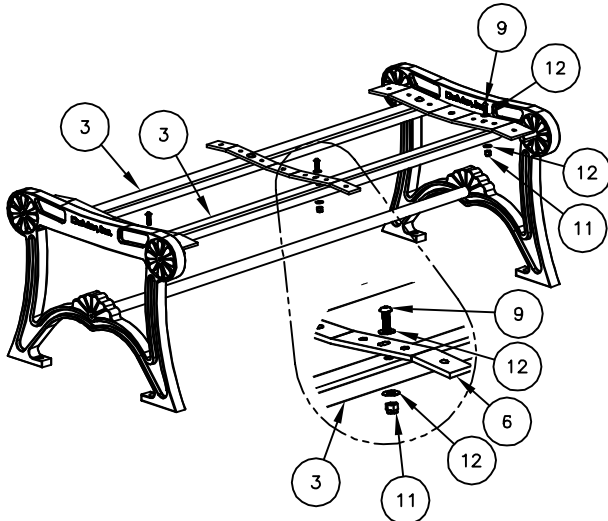

- ③ ATTACH SLATS TO STEP 2.

