

NOTES:

- 1.) ALL STL. MEMBERS COATED W/ ZINC RICH EPOXY THEN FINISHED W/ POLYESTER POWDER COATING.
- 2.) 1/2" X 3 3/4" EXPANSION ANCHOR BOLTS PROVIDED.

NOTES:

- 1.) DURING ASSEMBLY PROCEDURE;
DO NOT COMPLETELY TIGHTEN HARDWARE.
- 2.) THE ACTUAL PARTS WILL NOT BE NUMBERED.
NUMBERS ONLY APPLY TO DRAWING.
- 3.) UPON COMPLETION OF ASSEMBLY SQUARE
ALL COMPONENTS THEN TIGHTEN ALL HARDWARE.
- 4.) MOUNT AND ANCHOR AS SPECIFIED.

TOOLS REQ'D

- 3/4" WRENCH
- 1/2" WRENCH
- 1/2" MASONRY DRILL BIT
- DRILL

PARTS LIST FOR S-2

ITEM	QTY	PART NO	DESCRIPTION
1	1	0-520-00-01L	STL END SUPPORT, LEFT
2	1	0-520-00-01R	STL END SUPPORT, RIGHT
3	2	0-520-00VS-01	BACK SEAT END CAP, VS
4	1	0-520-60VS-02	6" STL SEAT FRAME, VS
5	4	1-11-068	1/2" X 1" SS CGE BOLT
6	4	1-20-018	1/2" SS THIN NYLON LOCKNUT
7	8	1-20-020	5/16" SS THIN NYLON LOCKNUT
8	4	1-22-015	1/2" SS FLAT WASHER
9	8	1-22-017	5/16" SS FLAT WASHER

KITS PROVIDED FOR S-2

ITEM	QTY	PART NO	DESCRIPTION
10	1	K-ANCO860-4	1/2" X 3 3/4" SS ANCHOR KIT (4PC)
11	1	K-CG0816-4TL	1/2" CGE BOLT HARDWARE KIT (4PC)
12	2	K-TLNUT05-4	5/16" THIN LOCK NUT HARDWARE KIT (4PC)

1 ATTACH END CAPS TO SEAT.

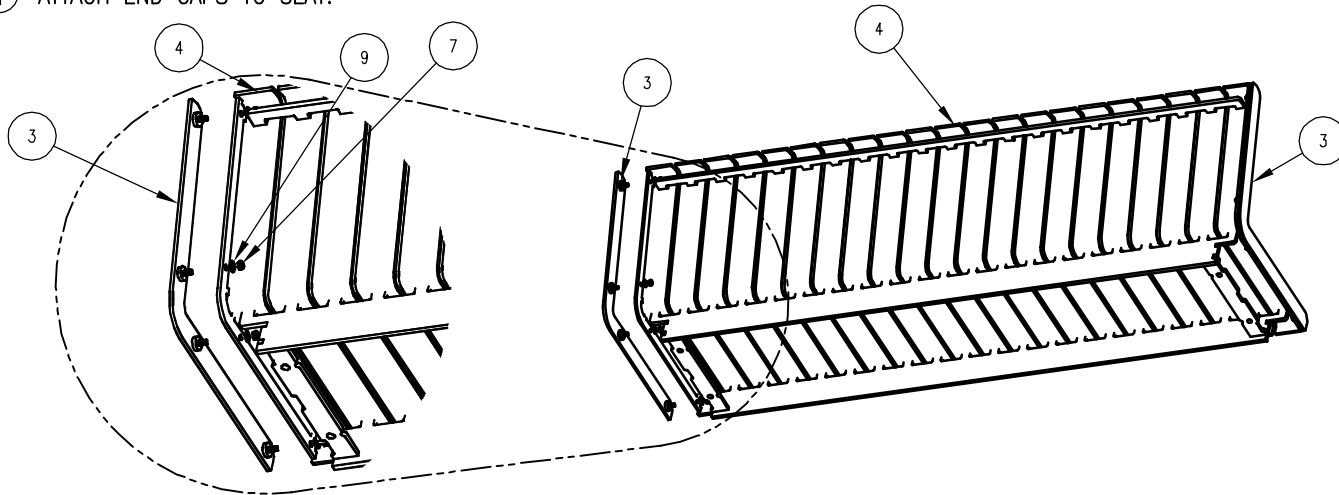

2 ATTACH SEAT TO SUPPORTS.

